

900 SERIES

CAPACITY: 700-3500 LBS. PER CASTER



6-908-TN



6-908B-TCI

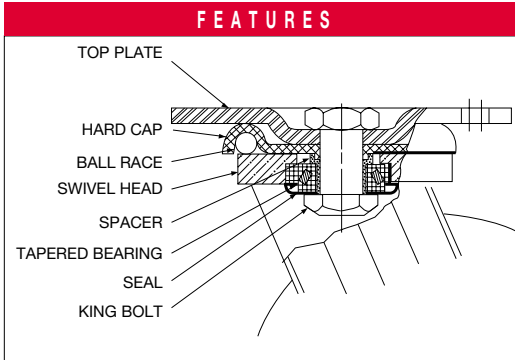

- 3/4" Axle
- 7/8" Grade 8 King bolt
- 4" Diameter upper raceway, 1/2" balls
- 5/8" Thick swivel head, precision machined and equipped with tapered roller bearings
- Ribbed legs for extra strength
- Grease fittings in swivel and wheel
- Bright zinc finish
- All swivel parts case hardened to Rockwell 62C

OPTIONS

- Brakes available. Add letter "B".
- Four Position Swivel locks. Add letter "F"
- Brakes and swivel locks cannot be combined on the same caster.

INSTALLATION

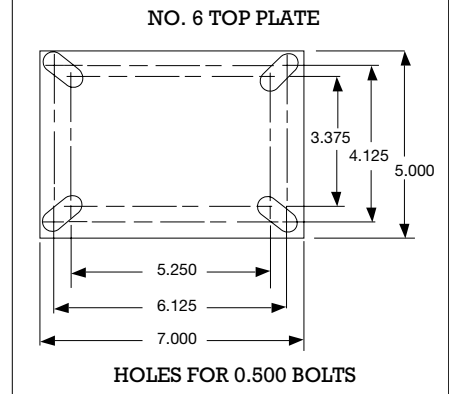

WHEEL DIAMETER	TREAD WIDTH	LOAD CAP./LBS	BEARING TYPE	SWIVEL MODEL	RIGID MODEL	SWIVEL RADIUS	OVERALL HEIGHT
SEMI-STEEL - CROWNED SEMI-STEEL CASTING							
6"	3"	3500	ROLLER	6-906-TCI	6-906R-TCI	5-1/4"	8-1/4"
6"	3"	3500	TAPERED	6-906-YCI	6-906R-YCI	5-1/4"	8-1/4"
8"	3"	3500	ROLLER	6-908-TCI	6-908R-TCI	6-1/4"	10-1/4"
8"	3"	3500	TAPERED	6-908-YCI	6-908R-YCI	6-1/4"	10-1/4"
10"	3"	3500	ROLLER	6-910-TCI	6-910R-TCI	7-1/4"	12-1/4"
10"	3"	3500	TAPERED	6-910-YCI	6-910R-YCI	7-1/4"	12-1/4"
12"	3"	3500	ROLLER	6-912-TCI	6-912R-TCI	8-1/4"	14-1/4"
12"	3"	3500	TAPERED	6-912-YCI	6-912R-YCI	8-1/4"	14-1/4"
URETHANE - FOR HEAVY LOADS AND ROUGH FLOOR CONDITIONS - ERGO*							
6"	3"	2500	ROLLER	6-906-TU	6-906R-TU	5-1/4"	8-1/4"
6"	3"	2500	TAPERED	6-906-YU	6-906R-YU	5-1/4"	8-1/4"
8"	3"	3000	ROLLER	6-908-TU	6-908R-TU	6-1/4"	10-1/4"
8"	3"	3000	TAPERED	6-908-YU	6-908R-YU	6-1/4"	10-1/4"
10"	3"	3500	ROLLER	6-910-TU	6-910R-TU	7-1/4"	12-1/4"
10"	3"	3500	TAPERED	6-910-YU	6-910R-YU	7-1/4"	12-1/4"
12"	3"	3500	ROLLER	6-912-TU	6-912R-TU	8-1/4"	14-1/4"
12"	3"	3500	TAPERED	6-912-YU	6-912R-YU	8-1/4"	14-1/4"
INDUSTRIAL WHEELS - HIGH QUALITY NATURAL RUBBER FOR EASE OF MOBILITY							
6"	3"	700	ROLLER	6-906-TN	6-906R-TN	5-1/4"	8-1/4"
8"	3"	900	ROLLER	6-908-TN	6-908R-TN	6-1/4"	10-1/4"
10"	3"	1100	ROLLER	6-910-TN	6-910R-TN	7-1/4"	12-1/4"
12"	3"	1200	ROLLER	6-912-TN	6-912R-TN	8-1/4"	14-1/4"

* Ergonomically designed for easy rolling.