

# 2 SERIES

Capacity up to 325 lbs each

## LoPro Top Plate Swivel & Rigid

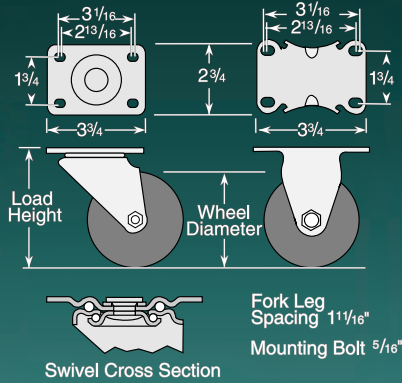

### Standard Features

- Zinc plated finish is attractive and durable
- Heat treated full double ball hardened raceways
- Low profile design offers low load height and quick swivel response.
- Ideal for business machines, stock picking carts, warehouse dollies and housekeeping carts
- Thread guards standard on all models, but are not available with 3" brake option

## Performance Options

### Caster Brake

**Side Lock** (See page 7)  
Easy to engage and disengage with a touch of the pedal (3" models only).  
To order specify "**BRK3**".

### Wheel Selection



2 SERIES

### 2 SERIES · LoPro Top Plate Swivel & Rigid · Capacity up to 325 lbs

Wheel Dia.	Tread Width	Capacity Each (Pounds)	Wheel Descriptions	Wheel Bearing	Swivel Top Plate Caster Models	Rigid Top Plate Caster Models	Load Height	Swivel Radius	Weight (Pounds)
2 1/2"	1 1/8"	120	Cushion Rubber	Nylon*	2.02689.44	2.02688.44	3 5/16	2 3/8	1
		175	Hard Rubber	Nylon*	2.02689.54	2.02688.54	3 5/16	2 3/8	1
		175	Polyolefin	Nylon*	2.02689.52	2.02688.52	3 5/16	2 3/8	1
3"	1 1/4"	125	Cushion Rubber	Nylon*	2.03689.44	2.03688.44	3 13/16	2 11/16	1 1/2
		210	Hard Rubber	Nylon*	2.03689.54	2.03688.54	3 13/16	2 11/16	1 1/2
		210	Polyolefin	Nylon*	2.03689.52	2.03688.52	3 13/16	2 11/16	1 1/2

\*Nylon bearing with powdered metal bushing.